

ENERGIZER 377

ZEROMERCURY®

SILVER OXIDE



Industry Standard Dimensions

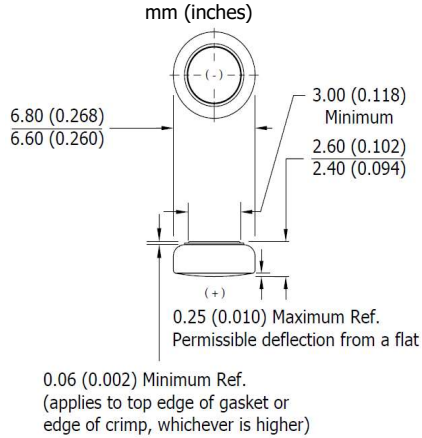

Specifications

- Chemical System:** Silver Oxide (Zn/Ag₂O)
- Designation:** ANSI/NEDA-1176SO, IEC-SR66
- Nominal Voltage:** 1.55 Volts
- Typical Capacity:** 24 mAh* (to 1.2 volts)
- Capacity Test:** 47K ohm continuous drain at 21°C
- Typical Weight:** 0.42 grams (0.015 oz.)
- Typical Volume:** 0.09 cubic centimeters (0.0063 cubic inch)
- Impedance (40 Hz):** 15 to 30 ohms

* Varies according to the applied load, temperature, and cutoff voltage.

Cross Section

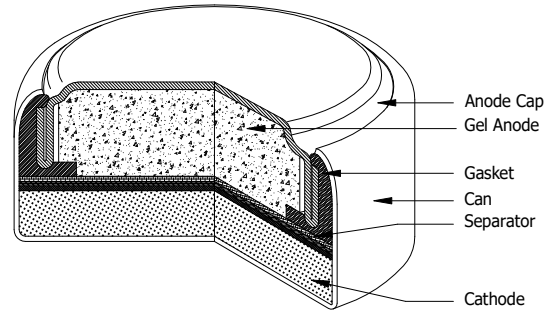

Typical Discharge Characteristics

Typical Performance at 21°C (70°F)

Schedule: Continuous
Typical Drain @ 1.46V:
 0.031 milliamperes
Load: 47K ohm



Schedule	Typical Drains at 1.46V (milliamperes)	Load (ohm)	Cutoff 1.2V (hours)
Continuous	0.031	47K	773

Temperature Characteristics

Typical Performance at Low Discharge Rates

Service Effects

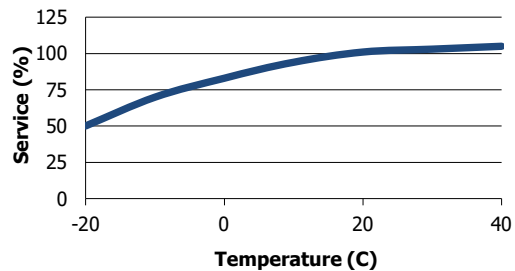

Storage Effects

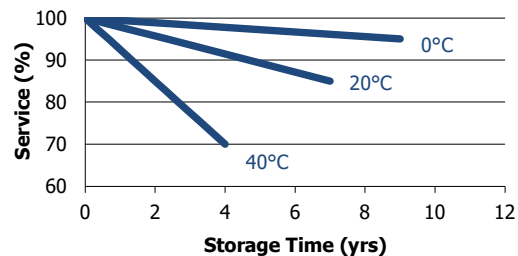

Important Notice

This datasheet contains typical information specific to products manufactured at the time of its publication.
Contents herein do not constitute a warranty and are for reference only.

ARTICLE INFORMATION SHEET

This Article Information Sheet (AIS) provides relevant battery information to retailers, consumers, OEMs and other users requesting a GHS-compliant SDS. Articles, such as batteries, are exempt from GHS SDS classification criteria. The GHS criteria is not designed or intended to be used to classify the physical, health and environmental hazards of an article. Branded consumer batteries are defined as electro-technical devices. The design, safety, manufacture, and qualification of Energizer and Rayovac branded consumer batteries follow ANSI and IEC battery standards.

SECTION 1 - DOCUMENT INFORMATION

Product Name: Energizer/Rayovac Battery

Document Number: 1019-SIOX

Chemical System: Silver Oxide (0Hg)

Date Prepared: October 2019

Designed for Recharge: No

Valid Until: October 2022

Prepared by: Energizer

SECTION 2 – COMPANY INFORMATION

Energizer Brands, LLC
533 Maryville University Drive
St. Louis, MO 63141

Email for Information:
energizer@custhelp.com
www.energizer.com

SECTION 3 – ARTICLE INFORMATION

Description	Silver Oxide Battery (0HG)
Use	Portable power source
Brand	ENERGIZER RAYOVAC
IEC Designations	Including but not limited to: SR42, SR44, SR58, SR60, SR68, SR69, SR66, SR43, SR54, SR55, SR41, SR48, SR57, SR59
Sizes	Including but not limited to: 315Z, 317Z, 319Z, 321Z, 329Z, 335Z, 337Z, 341Z, 344/350Z, 346Z, 357/303HZ, 357/303Z, 362/361Z, 364/363Z, 365Z, 371/370Z, 373Z, 377/376Z, 379Z, 386Z, 387SZ, 390/389Z, 391Z, 392/384Z, 393Z, 394/380Z, 395/399Z, 397/396Z, EPX76Z, A76ZINS
Image	

SECTION 4 – ARTICLE CONSTRUCTION

IMPORTANT NOTE: The battery should not be opened or burned. Exposure to the ingredients contained within or their combustion products could be harmful.

MATERIAL OR INGREDIENT	PEL (OSHA)	TLV (ACGIH)	%/wt.
Graphite (CAS# 7782-42-5)	15 mg/m ³ TWA (total dust) 5 mg/m ³ TWA (respirable fraction)	2 mg/m ³ TWA (respirable fraction)	0-3
Manganese Dioxide (CAS# 1313-13-9)	5 mg/m ³ Ceiling (as Mn)	0.2 mg/m ³ TWA (as Mn)	0 - 20
Potassium Hydroxide (CAS# 1310-58-3)	None established	2 mg/m ³ Ceiling	0 - 7
Silver Oxide (CAS# 20667-12-3)	0.01 mg/m ³ TWA (as Ag)	0.1 mg/m ³ TWA (as Ag)	10 - 35
Sodium Hydroxide (CAS# 1310-73-2)	2 mg/m ³ TWA	2 mg/m ³ Ceiling	0-7
Zinc (CAS# 7440-66-6)	15 mg/m ³ TWA PNOR* (total dust) 5 mg/m ³ TWA PNOR* (respirable fraction)	10 mg/m ³ TWA PNOC** (inhalable particulate) 3 mg/m ³ TWA PNOC** (respirable particulate)	6 - 14
Non-Hazardous Components Steel (iron CAS# 65997-19-5) Water, Paper, Plastic and Other	None established None established	None established None established	30 - 35 Balance

* PNOR: Particulates not otherwise regulated

**PNOC: Particulates not otherwise classified

All Energizer Silver Oxide have zero added mercury.

Applicable Battery Industry Standards

North America Standards	ANSI C18.1M Part 1	ANSI C18.1M Part 2	ANSI C18.4
International Standards	IEC 60086-1	IEC 60086-2	IEC 60086-5

SECTION 5 – HEALTH AND SAFETY

Ingestion: Do not induce vomiting or give food or drink. Seek medical attention immediately. CALL NATIONAL BATTERY INGESTION HOTLINE for advice and follow-up (202-625-3333) collect day or night.

The following instructions apply to exposure of internal components.

Inhalation: Provide fresh air and seek medical attention.

Skin Contact: Remove contaminated clothing and wash skin with soap and water. If a chemical burn occurs or if irritation persists, seek medical attention.

Eye Contact: Immediately flush eyes thoroughly with water for at least 15 minutes, lifting upper and lower lids, until no evidence of the chemical remains. Seek medical attention.

SECTION 6 – FIRE HAZARD & FIREFIGHTING

Article Information Sheet



Page 3 of 4
Silver Oxide Batteries

In case of fire, it is permissible to use any class of extinguishing medium on these batteries or their packing material. Cool exterior of batteries if exposed to fire to prevent rupture.
Fire fighters should wear self-contained breathing apparatus.

SECTION 7 - HANDLING AND STORAGE

Storage: Store in a cool, well ventilated area. Elevated temperatures can result in shortened battery life.

Mechanical Containment: If potting or sealing the battery in an airtight or watertight container is required, consult your Energizer Brands, LLC representative for precautionary suggestions. Batteries normally evolve hydrogen which, when combined with oxygen from the air, can produce a combustible or explosive mixture unless vented. If such a mixture is present, short circuits, high temperature, or static sparks can cause an ignition.

Do not obstruct safety release vents on batteries. Encapsulation (potting) of batteries will not allow cell venting and can cause high pressure rupture.

Handling: Accidental short circuit for a few seconds will not seriously affect the battery. Prolonged short circuit will cause the battery to lose energy through heating, and can cause the safety release vent to open. Sources of short circuits include jumbled batteries in bulk containers, metal jewelry, metal covered tables or metal belts used for assembly of batteries into devices.

Soldering directly to a battery is not recommended. If welding to the battery is required, consult your Energizer sales representative for proper precautions to prevent seal damage or short circuit.

Charging: This battery is manufactured in a charged state. It is not designed for recharging. Recharging can cause battery leakage or, in some cases, high pressure rupture. Inadvertent charging can occur if a battery is installed backwards.

Labeling: The label acts as an electrical insulation for the battery can. Damage to the label can increase the potential for a short circuit.

WARNING: do not install backwards, charge, put in fire, or mix with other battery types. May explode or leak causing injury. **Replace all batteries at the same time.**

SECTION 8 – DISPOSAL CONSIDERATIONS

Dispose of in accordance with all applicable federal, state and local regulations. Appropriate disposal technologies include incineration and land filling.

SECTION 9 – TRANSPORT INFORMATION

In general, all batteries in all forms of transportation (ground, air, or ocean) must be packaged in a safe and responsible manner. Regulatory concerns from all agencies for safe packaging require that batteries be packaged in a manner that prevents short circuits and be contained in "strong outer packaging" that prevents spillage of contents. All original packaging for Energizer alkaline batteries has been designed to be compliant with these regulatory concerns.

Silver oxide batteries (sometimes referred to as "Dry cell" batteries) are not listed as dangerous goods under the ADR European Agreement Concerning the International Carriage of Dangerous Goods by Road, the IMDG International Maritime Dangerous Goods Code, UN Dangerous Good Regulations, IATA Dangerous Goods Regulations, ICAO Technical Instructions and the U.S. hazardous materials regulations (49 CFR). These batteries are not subject to the dangerous goods regulations provided they meet the requirements contained in the following special provisions.

Regulatory Body	Special Provisions
ADR	Not regulated
IMDG	Not regulated
UN	Not regulated
US DOT	49 CFR 172.102 Provision 130
IATA	A123
ICAO	Not regulated

All Energizer silver oxide batteries are packed in such a way to prevent short circuits or the generation dangerous quantities of heat and meet the special provisions listed above. In addition, the IATA Dangerous Goods Regulations and ICAO Technical Instructions require the words "not restricted" and the Special Provision number A123 be provided on the air waybill, when an air waybill is issued.

For emergency information call ChemTel 1-800-526-4727 (North America) or 1-314-985-1511 (International).

SECTION 10 – REGULATORY INFORMATION

10A Battery

1. **SARA/TITLE III:** As an article, this battery and its contents are not subject to the requirements of the Emergency Planning and Community Right-To-Know Act.
2. **USA EPA Mercury Containing & Rechargeable Battery Management Act of 1996:** No mercury added
3. **EU Battery Directive 2006/66/EC Amended 2013/56/EU:** Energizer batteries are compliant with all aspects of the Directive

10B General

1. **CPSIA 2008:** Exempt
2. **US CPSC FHSA (16 CFR 1500):** Not applicable since batteries are defined as articles
3. **USA EPA TSCA (40 CFR 707.20):** Not applicable since batteries are defined as articles
4. **USA EPA RCRA (40 CFR 261):** Classified as non-hazardous waste per ignitable, corrosive, reactive or toxicity testing
5. **California Prop 65:** No warning required
6. **DTSC Perchlorate labeling:** No warning required
7. **EU REACH SVHC:** No REACH listed substances of very high concern are present above 0.01% w/w

10C Article Definitions

1. **OSHA Hazard Communication Standard, Section 1910.1200(c)**

SECTION 11 – GHS OTHER INFORMATION

None

Acronym Glossary

[ANSI](#): American National Standards Institute
[CPSC](#): Consumer Product Safety Commission
[CPSIA](#): Consumer Product Safety Improvement Act
[DTSC](#): Department of Toxic Substances Control
[EPA](#): Environmental Protection Agency
[FHSA](#): Federal Hazardous Substances Act
[GHS](#): Globally Harmonized System for Hazard Communication
[IEC](#): International Electrotechnical Commission
[OSHA](#): Occupational Safety and Health Administration
[RCRA](#): Resource Conservation and Recovery Act
[SDS](#): Safety Data Sheet
[SVHC](#): Substances of Very high Concern
[TSCA](#): Toxic Substances Control Act

Energizer has prepared copyrighted Article Information Sheets to provide information on the different Eveready/Energizer/Rayovac battery systems. Batteries are articles as defined under the GHS and exempt from GHS classification criteria (Section 1.3.2.1.1 of the GHS). The information and recommendations set forth herein are made in good faith, for information only, and are believed to be accurate as of the date of preparation. However, ENERGIZER BRANDS, LLC MAKES NO WARRANTY, EITHER EXPRESS OR IMPLIED, WITH RESPECT TO THIS INFORMATION AND DISCLAIMS ALL LIABILITY FROM REFERENCE ON IT.